

Scots n' Water

OFFICIAL PUBLICATION OF THE FLYING SCOT SAILING ASSOCIATION

VOLUME XXIX, NUMBER 2, MARCH/APRIL, 1987

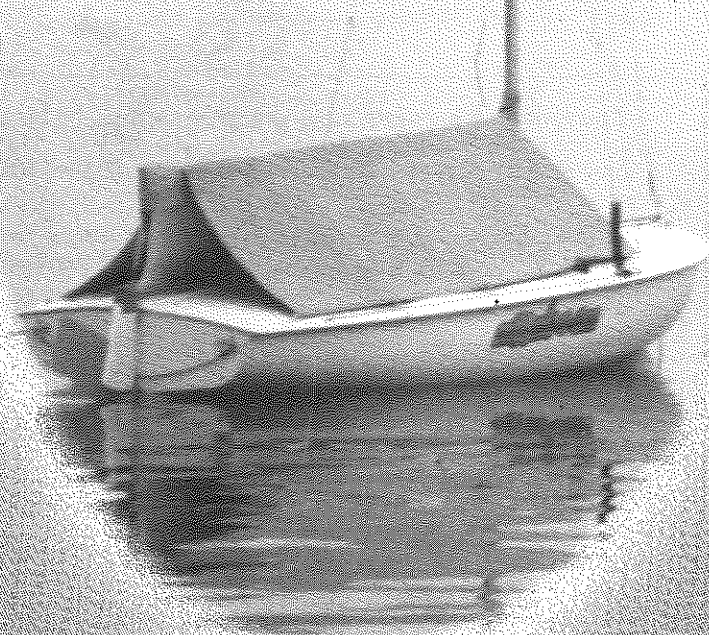

Flying Scot Fleet One and the Gordon Douglass Boat Company
Invite you to a SPECIAL REGATTA CELEBRATION of

THE 30th ANNIVERSARY OF THE FLYING SCOT CLASS

at Cowan Lake Sailing Association,
Wilmington, Ohio, June 27 & 28, 1987

Those of us who attended the 25th Anniversary Regatta remember the good times had by one and all despite the light air. We can guarantee the 30th Anniversary to be an even more festive occasion. It is too early at the time of this writing (January 10) to know how many Scots will be in attendance but with two championships and the regatta title on the line, you can bet it will top the 52 boats that attended the 25th. Host fleet 1 has been working hard to insure a good time both on and off the water. Registration and launching will begin at noon on Friday, June 26. There are a small number of dock spaces available - assigned on a first come first serve basis. Early arrivals can expect to spend Friday afternoon day sailing on Lake Cowan, chatting with Eric and Sandy, and helping the host fleet to get the party atmosphere rolling. Arrangements have been made for a group feed at a local restaurant Friday night.

On Saturday morning, registration and launching will continue with a skippers' meeting at 10:30 and our first race at 11:00 a.m. Lunches will be available at the cost of \$1 per person and we will have free beer and soft drinks throughout the weekend. Free coffee and doughnuts will also be available both mornings. The second race will be at 2:30 p.m. on Saturday followed by a famous Fleet One Pig Roast (two tickets are included in the registration fee - extra tickets are \$9.00 each). There also will be an evening entertainment program. On Sunday morning, we will have our third and final race at 9:30 a.m. with the awards ceremony to follow.

The fleet will be divided into three divisions. The first division will sail for the 30th Anniversary Title, the Ohio District Championship (highest finishing Ohio District members), and the National Husband & Wife Championship (highest finishing boats sailed by a husband and wife team only). The other two divisions will be the 30th Anniversary Challenger Division (trophies go 10 deep) and the Husband & Wife Challenger Division (trophies go 10 deep). Participants will be allowed to choose their division at registration. However, a one race elimination may be held if the split is too lopsided.

Finally, appropriate sacrifices to the weather gods are being made weekly to reduce the chance of rain to 1/10th of 1 percent and increase the chance of wind to at least 50 percent with a guarantee for at least as much as we had at the 25th. So with perfect weather, a large fleet in attendance and an internationally famous Fleet One Pig Roast, there is no reason for you to be anywhere else on June 26 - 28 except at the 30th Anniversary Regatta.

Special Attractions

- Sandy Douglass - our designer and mentor in attendance
- 45 trophies + crew trophies, three divisions, two championships plus the regatta title up for grabs.
- Gigantic celebration party and feast on Saturday evening
- Free camping at the CLSA, motels available (not so free)
- Low registration fee of only \$30.00 including dinner for two - that's only \$1.00 for every year we have to celebrate!!



Information: Directions, lodging details, etc. may be obtained by writing to Chuck Hoffman, 4493 Bridlewood, Batavia, OH 45103. Home phone 513-752-4024. Some charter boats are available - inquire for details. **Register Early!!**

Name _____ Sail No. _____

Address _____

Please send complete information about the 30th Anniversary Regatta.

We'll be there! Enclosed is a check for \$30 early registration fee (\$40 after May 15, 1987) - includes two tickets to the Pig Roast.

I can't bring my boat but I love the Flying Scot and want to be there for the party. I will have _____ in my party.

I think there will be a total of _____ people in my party at the Pig Roast.

Flying Scot® Sailing Association

3008 Millwood Ave.
Columbia, S.C. 29205
803-252-5646

PRESIDENT

Jack Stewart*
88 Overlook Drive
Alliance, OH 44601
(216) 823-7885

FIRST VICE-PRESIDENT

E. Paul Moore*
317 Country Club Drive
Ballwin, MD 63011
(314) 227-6700

SECOND VICE-PRESIDENT

Lawrence Taggart*
5809 Memphis Street
New Orleans, LA 70124
(504) 482-7358

TREASURER

Charles L. Dees
930 Seaclyff Drive
Fairhope, AL 36532
(205) 928-8942

MEASURER

Harry Carpenter
204 N. Eleventh Street
Oakland, MD 21550
(301) 334-8329

COMMODORE

Dr. Hallam Walker*
P.O. Box 2185
Davidson, NC 28036
(704) 892-1276

IMMEDIATE PAST COMMODORE

Allen M. Douglas
P.O. Box 752
Panama City, FL 32401
(904) 785-7500

DESIGNER

Gordon Douglass
P.O. Box 28
Oakland, MD 21550
(301) 334-4841

EXECUTIVE SECRETARY

Ed Eubanks
3008 Millwood Avenue
Columbia, SC 29205

*Denotes Executive Committee Members

Scots n' Water

34090 Parkdale
Livonia, MI 48150

EDITOR, PAT BARRY

(H) (313) 427-0797 (after 4:30 pm)
(O) (313) 451-6600 (leave message)

LAYOUT DESIGN: NANCY H. COOPER

Cover: Pat Barry's "Moonbeam" emerges from an early morning fog on Crystal Lake in Michigan.

CONTENTS

March/April 1987

Volume XXIX, Number 2

2 30TH ANNIVERSARY OF FLYING SCOT

4 LETTERS TO THE EDITOR

7 THE FLEET REVIEW
FLEET BUILDING

9 FLEET BEAT

10 MID-LINE SAG

12 REGATTA SPOTLIGHT

13 WHEN THE SUN GOES DOWN

14 1987 FS MIDWINTER CHAMPIONSHIP

15 THE FLEET'S IN

18 1987 NORTH AMERICAN CHAMPIONSHIP

22 THE STARTING LINE

23 CAVEAT EMPTOR

This will be the final issue of Scots n' Water you will receive unless your 1987 dues are paid.

Scots n' Water

Registered Trademark. Publication No. ISSNS 0194-5637. Published bi-monthly by FSSA at 3008 Millwood Avenue, Columbia, South Carolina 29205. Volume XXIX, No. 1. Subscription is \$8 a year included in annual membership dues. Second class postage paid at Columbia, South Carolina 29201.

Publication Deadlines: May issue, March 1; July issue, May 1; September issue, July 1; November issue, September 1; January issue, November 1; March issue, January 1

Ad Rates: Write FSSA, 3008 Millwood Avenue, Columbia, SC 29205

Postmaster: Please send change of address to FSSA, 3008 Millwood Avenue, Columbia, South Carolina 29205.

Letters to the Editor

Dear Pat,

This is my third year as owner of FS 367, built in 1962. I find that the insurance rates have risen ridiculously within this period of time. In 1984 the premium was \$141 with a \$120 deductible. In 1985 it rose to \$207 with a \$200 deductible. In 1986 it rose to \$297 with a \$500 deductible! And this is not merely placed with a random company or broker but with an agent who was at one time listed as FSSA sponsored and who claimed understanding of the Flying Scot owner and his needs.

I feel that these costs are quite out of proportion to the value of the boat and even in light of their claim of "new for old" replacement, the \$500 deductible precludes ever collecting for anything except in the case of an almost total loss.

The reason given for this high cost is the age of the boat. Yet, what is there on the Flying Scot to actually deteriorate with age? Apart from replacing worn lines and occasionally purchasing a new suit of sails, the Scot is a very basic vehicle with probably fewer working parts to wear out than a bicycle.

I would like to suggest that the FSSA investigate the possibility of arranging and offering to members a realistically-priced group insurance policy to cover their boats and provide basic liability coverage.

I would be curious to know how other owners of older Scots cope with this situation.

Richard C. Lewis
Brooklyn, NY

Dear Richard,

I think sailing is falling prey to the recent 'insurance crisis' that we have all read so much about.

I talked with several people about your problem. None of them reported paying anything near what you have been asked to pay.

It is true that the FSSA did for a long period of time recommend a particular agent and underwriter for its members. I'm not sure if that is who you are referring to. Ed Eubanks determined several years ago that we would no longer do that. He cited many reasons, but one of them was the feedback he received from many members who had insured with this company for years, often with no claim, only to find the premiums and deductibles increasing to alarmingly high amounts.

The FSSA currently has no plan to offer. I will forward this idea to Ed Eubanks for his consideration. It probably would be a good service to members if we could arrange it. (Any agents out there? 'May wish to contact Ed, too!')

In the meantime, let me suggest two alternatives. First, shop around locally. I found great differences in price in the Detroit area. But no one I know is paying anywhere near what you are. (I myself paid \$75 last year for a policy on a new boat, which is considerably more costly to replace than is your older boat.)

Another option is to join USYRU and convince at least two other Scot owners around you to sign up with their insurance program. I am told it is very good and is very reasonable. You can get further information by writing to USYRU at Box 209, Newport, RI 02840 or calling them at (401) 849-5200.

If there is a member in the Class that has discovered an alternative policy for an older Scot, let me know. I will forward the information to Richard.

My strongest advice would be to 'Shop Around,' Richard. I'm sure there are better deals around!



Dear Class Members,

Do you know the woman in the left of this picture?

During the past several issues of the magazine she has been identified as a Ms. Burton, Ms. Bufton, and Ms. Bertch. The people in the background of the picture look nearly as confused as I. Perhaps the people she's standing with could identify this person who seems to be suffering from a serious identity crisis.

Thank you for your assistance.

Pat Berry
Editor

Dear Pat,

You always do a fine job with regatta reports and especially with your emphasis on publishing crew names so that they get the credit they deserve.

As many Scot sailors know, I am lucky to have Kathy Kennedy and Monica Berton racing with me. They are outstanding crew and party as hard as they sail! (Harder. Ed.) Unfortunately, some 'gremlins' have crept into your typewriter, and Monica's last name has been misspelled as "Burton," "Bufton," and even "Bertch" in recent issues.

Just to set the record straight, her last name is "Berton." Although she has a great sense of humor, she asks me to warn you to get it right next time or look out for a spinnaker pole in your ear!

Dan Goldberg
Pittsburgh, PA

Dear Dan,

Thank you for clearing up this mystery. Forever more we will rightly identify her as Kathy Burton. I'm sure if I was her, I would be as upset as Ms. Bufton obviously is. I mean, really Class members, do you find Ms. Bertch's threat of bodily harm all that "humorous"?

I, for one, am grateful to know who this woman is. At least I will know how to spell her name should I need to file a suit for 'Malicious use of a spinnaker pole in a manner not intended by its manufacturer.' Monica Berton, right? Or is it. . .

Pat Barry
Editor

Dear Pat,

In your September/October issue of *Scots n' Water* you published an article featuring Dr. Bill Singletary in your Member Profile section. Dr. Singletary is a member of our local yacht club, Lake Townsend YC, and has many non-Scot sailing friends within the club. For this reason I would like to share the article in our local newsletter. On a personal note, I found the article of particular interest since I am currently sailing FS 801, Bill's first Scot.

On another note, I found the letter written by the Kleemans in the November/December issue to be representative of the concerns of most one-design sailors. The competitive aspect of our common interest in sailing is the key reason that we maintain a common governing body, yet we all realize the many other beneficial aspects of sailing. The prob-

(continued on page 5)

LETTERS

(Continued from page 4)

lem of how to increase interest in one-design sailing is beyond the control of a single person or class. I do not know of any active one-design sailor who understands how a person or family can own a sailboat and *not* sail. Those of us who routinely race and/or sail for recreation are the wrong people to solicit about how to increase class participation, yet we are the only ones who can implement a revitalization plan within our class.

One suggestion that I would like to make is that we should make our fellow Flying Scot sailors who are not active in a local club aware of ongoing activities. I realize that a number of activities are listed in The Starting Line, but I believe that we have a number of 'closet sailors' who need a more personal push to participate locally. If FSSA provided each fleet captain a listing of all the registered Scots currently residing in a location with an active fleet, the captains and members of the fleet could personally contact these people and make them aware of local activities. If this mechanism to improve involvement was successful with our own class, it could be expanded to other classes at the local level through the cooperation of manufacturers, local dealers, and class associations.

Fields C. Gunsett
Greensboro, NC

Dear Fields,

Hope your club enjoys reading about Dr. Bill Singletary as much as we all did!

You are right, many 'unattached' Scot sailors do not get involved in local activities. And, too, active sailors may not be the best people to ask as to why that is. I have some ideas for you.

First, whenever Gordon Douglass Boat Company builds a boat, they get the number from the FSSA. They also, I understand, send the FSSA the name/address of the new owner. I further understand that the FSSA office is supposed to periodically send this information about new owners - whether or not they've joined the FSSA - to the appropriate District Governor. From there, the governor is supposed to send the information out to the appropriate fleet captain, who, I suppose, would want to contact the new owner and solicit their activity with the club/fleet. If this is not happening in your area, let Ed Eubanks know.

Second, Scots n' Water prints New Members expressly for the purpose of a direct contact by, hopefully, both the Governor and the Fleet Captain. Otherwise,

SCOTS N' WATER

MICHELOB SAILING



INSTRUCTIONAL VIDEO

Gary Jobson, leading sailing authority and tactician in the 1977 America's Cup victory, provides first class instruction on basic sailing techniques for the beginning or novice sailor. At only **\$14.95, MICHELOB SAILING** makes the perfect first lesson!

CALL TOLL FREE
1-800-972-5858
Operator 220
BCS1-SC
or use the convenient
order blank below.

Please send me _____ copies of **Michelob Sailing** at \$14.95 each (plus \$3.95 SHIPPING/HANDLING).
(Check Format) VHS Beta

NAME _____
ADDRESS _____
CITY _____ STATE _____ ZIP _____
 CHECK MONEY ORDER MASTERCARD/VISA
CARD NO. _____ EXP. DATE _____
SIGNATURE _____

MAIL YOUR ORDER TO:
**MICHELOB SAILING TAPE, P.O. BOX 708, BCS1-SC
NORTHBROOK, IL 60065**

Missouri and Illinois residents please add applicable sales tax.
Allow 4 to 6 weeks for delivery. Please do not send cash.

there is no reason to print them! Another source of information, then.

Third, I would go to your local dealer and see if he/she would not agree to send you a postcard everytime a new/used Scot is sold in the area. A contact could be made from that. Further, your local club/fleet could put together a simple 'promo' that could be left with the dealer to be given to the new, happy owner upon delivery of the boat. 'Hooking' the new owner is a lot simpler during that period of excitement.

Fourth, you could survey Scot sailors in the area as to why they don't join/sail with you and what their needs are. My own fleet did that last summer. Then be sure to follow up with activities designed for them!

Finally, how about a 'promo pack' that could be assembled and stored in a zip-lock bag? Give one or more to each fleet member with the encouragement to carry it on board and/or in the car. Then when a 'UFS' is spotted, the member can at least leave the packet, even if it is only gray-taped to the mast.

I agree with you. In the final analysis, it is up to the local fleet to promote themselves, the Scot, and Scot sailing.

Good luck!

Dear Pat,

I would like to sound off on the use of Mylar/Kelvar sails for the Scot. Sail makers are constantly improving and refining their product. The sails we have today are faster than they were ten years ago.

Is this good or bad? It's OK to a point. The main reason for this refinement by sailmakers is so they can have an advantage over their competition. To be competitive, one would have to buy the faster sail. Thus, more sails are sold. This does not benefit a class, only sail makers. It is counter-productive and contrary to the philosophy of "one-design."

We should limit our choices of sail as we do hull and rigging. Mylar/Kelvar sails would cause a division in our class. We don't need that. Besides, they are ugly and would spoil the beauty of the Scot, both aesthetically and emotionally.

I find it hard to believe that Dacron is going out of production. There are many other uses for this cloth besides sails. I would like to ask everyone who owns and loves a Flying Scot to voice their opinion to Measurer Harry Carpenter soon.

Gus Chennells
Orlando, FL

Consistently Out Front



1ST Carolina's Distrist
 1ST Hoover Buckeye
 1ST Berlin Yacht Club Regatta
 1ST Challenger Division NAC
 4 out of top TEN at NAC's

Schurr Sails are the highest quality sails fabricated with the highest quality materials and American know how.

The sailmakers at Schurr Sails have more than 50 years of accumulated experience in the Flying Scot Class.

Whether you race or cruise, we deliver the quality of service that you deserve and appreciate.

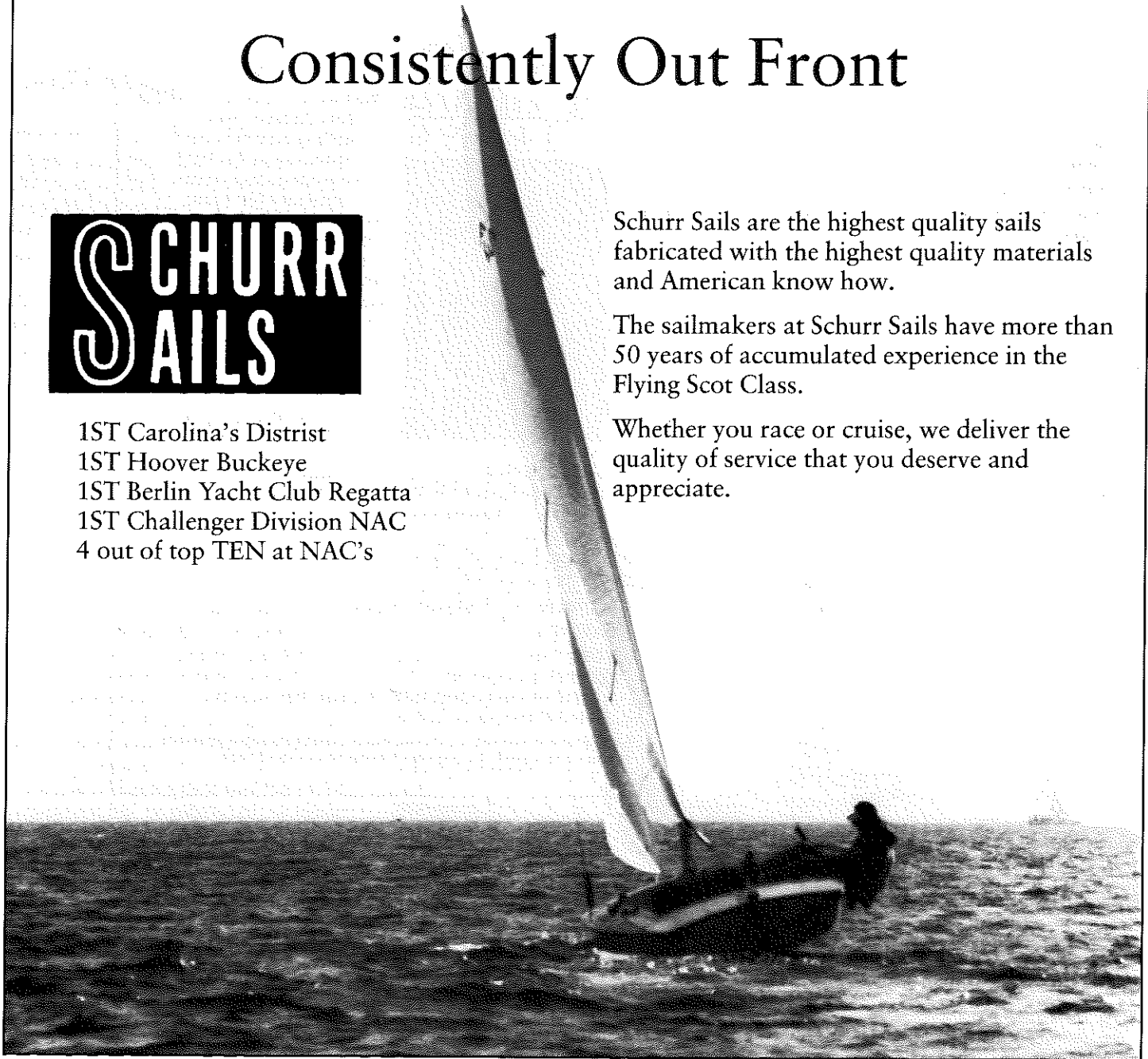

SAIL # _____

Number Color () Red; () Blue; () Green; () Black

- | | |
|-------------------------------|---------------------------------|
| () 4.4 oz. Racing Cloth | () 5 oz. Cruising Cloth |
| () Main \$415 | () Spin. Crosscut \$280 |
| () Mainsail Reef \$35 | () .5 oz. Dynac Spin. \$310 |
| () Mainsail Foot Shelf \$30 | () Spin. Triradial \$365 |
| () Jib \$190 | () Brummels on Spin. \$10 |
| () Telltale Window ea. \$10 | () Centerboard Gaskets \$12 |
| () Vision Window ea. \$15 | () Deluxe Tapered Battens \$22 |
| () Mainsheet Retainer \$8.50 | () Kevlar Spin. Trims \$65 |

Name _____

Address _____

City _____

State _____ Zip _____

Daytime Phone _____

Comments (repair) _____



- Spinnaker Colors
- Red
 - Green
 - Lt. Blue
 - Dk. Blue
 - Purple
 - Orange
 - West Coast Gold
 - Black
 - White
 - Yellow

Price includes bag, battens and royalty.

Terms: Pay order in full, Schurr Sails will pay freight or 50% deposit w/order, Sails shipped C.O.D. for balance.

Mail ORDER form to: Schurr Sails, Inc. 490 South "L" Street • Pensacola, Fl. 32501 • (904) 438-9354

The Fleet Review

Fleet 160

Blue Ridge Mountains

John Beery

Fleet 160 is the newest fleet in the Association having been chartered on October 25, 1986. The charter members, Bob Post (our first Scot owner), Clive Watson, Dick Smith, and myself have the distinction of being the first new fleet since the 'Fleet Building' issue of *Scots n' Water* a year ago this month. We'll have to settle for that distinction for the time being since all the other honors are currently taken!

Our home water is beautiful 550 acre Lake of the Woods. Aptly named, it is nestled in the foothills of the Blue Ridge Mountains. The area around LOW is steeped in history. Most notable is the site of the Wilderness Battle in the war between the states, with Chancellorsville just a few miles away.

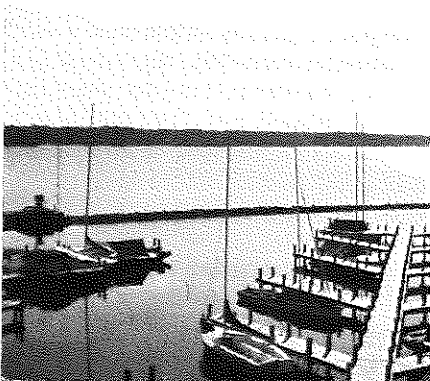

Marina facilities allow for easy access to the lake.

Members of the fleet belong to the Lake of the Woods Sailing Club which is going on eight years old. During the past several years the club has searched for the 'right' club boat and considered many different classes. Thanks to Bob, that search is over. We expect most members of the club to convert to Scots. In fact, the fleet has already grown 20% with the addition of our fifth boat and its owner George Burgess.

LOWSC annually holds a Spring and Fall series. Each has fourteen races with three throw-outs. We also host an open regatta on the last Saturday of each April. The racing culminates in the awarding of the high-point Wilderness Cup each season. While racing is important, we try to plan 'fun' events such as our annual 'Round-the-Island Fun in the Sun Day' each summer.

SCOTS N' WATER

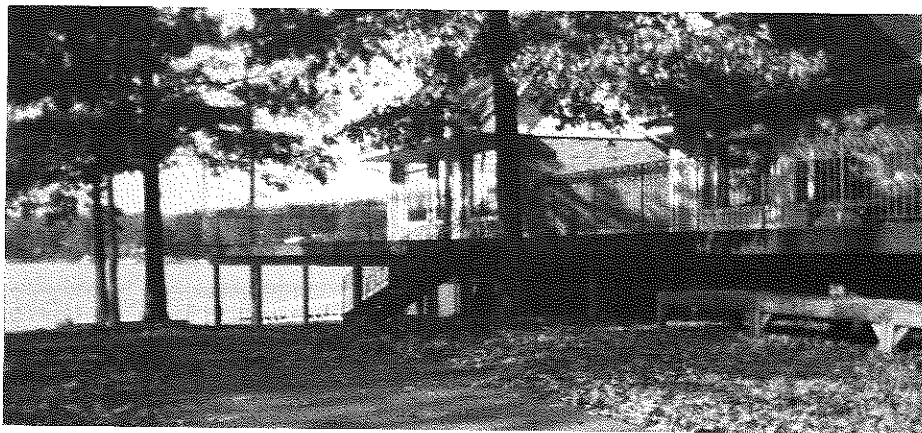

A beautiful, modern clubhouse overlooks our sailing site.

Several of us travel to every event possible, including the NAC's. Bob has been to the last two and was spotted in FS 3201 in the November, 1986 issue. We plan to attend Mid-Winters and the 30th Anniversary Regatta this year.

The 'Fleet Building' issue was a big help to us. We're going to employ many of the ideas suggested to increase membership. Our current prescription for success is simple: the club is the foundation. Regattas and races must be properly run and the club must be highly visible. Throw in the right boat, communication with members, a little esprit, and some good

sailing weather and the rest takes care of itself.

We hope to meet many Association members at regattas this year and hope that many will consider coming to our regatta this April. While we're new, we promise we'll be good!

If there were an award for 'most spirited newcomer', John would surely earn it. In the space of just a month after the chartering of their fleet Scots n' Water received three entries from new Captain, John Beery. With this enthusiasm, it is clear that Fleet 160 will be a strong addition to our Class. Congratulations John, Bob, Clive and Dick on a great start! And Welcome Aboard!

FLEET BUILDING

Plan A Rigging Party!

Pat Barry

Is your fleet looking for a way to bring people together, have fun, and accomplish something early in the season? Then schedule a 'rigging party!'

Picking up on the idea from other clubs around the country I suggested the idea of a rigging party to my fleet, #20, last year. Well-received, it was set for the Saturday a week earlier than our first race date. We set the next day, Sunday, as a backup. Gladly, we did not have to use it. And just as gladly, our first time was both successful and fun.

The advantages of such a work party are numerous. Socially, it accomplishes

many important things that are conducive to a strong fleet. First, it brings old fleet members together. Second, it is a great place to introduce new fleet members. Third, it is ideal for drawing non-fleet members into the fleet as you can offer the help they often need in rigging, but in a very friendly and non-intimidating social setting. A pot-luck at mid-day serves to pull people together for some conversation before completing the process that afternoon. In fact, some people that couldn't participate all day at our rigging party came just for the pot-luck!

(continued on page 8)

FLEET BUILDING
(continued from page 7)

The event also helps the sailing/racing program. Other eyes can often notice the missing nut or frayed wire that we might miss. It is a great way to get rigging and tuning advice from the best sailors in the fleet. Mast rake, jib adjustments, rudder angle, etc., can all easily be examined and advised by the best sailors. With just a little more planning, the top sailors could conduct a short mini-clinic on boat tuning and adjustments right on shore before the day ended. With a starting date before the first races, the rigging party helps to insure a greater turn-out earlier in the racing season — no more

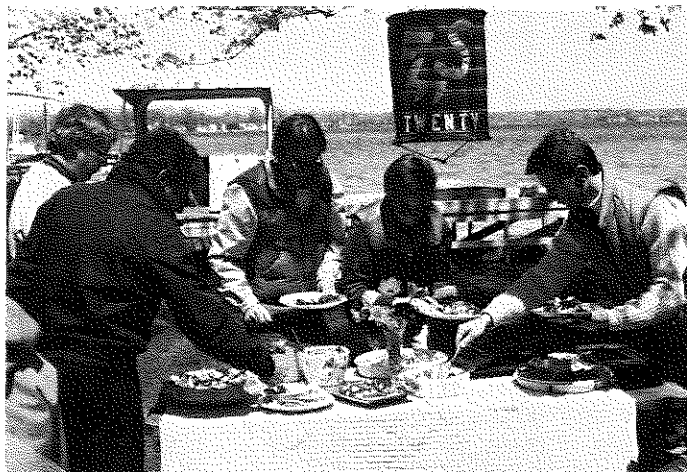

The potluck is a natural draw.



Helping hands are really appreciated.

“my boat’s not in the water yet” excuses!

Finally, of course, many hands make light work in getting boats uncovered, equipment stowed, masts raised, sails attached, hoists and boats in the water, and trailers stored. A tedious task, it is accomplished faster and much more enjoyably.

Plan now. Publicize the date and time. Invite new sailors or unaffiliated Scot sailors. Call a few days before to ‘remind’ and set the pot-luck menu. You’ll have a great time and will get the season off to a successful and sociable start. Rig on; together!



IF YOUR SAILMAKER IS THE ONLY ONE THAT CAN MAKE HIS SAILS GO FAST, MAYBE YOU NEED ANOTHER SAILMAKER. NORTH SAILS 5 OF TOP 7 AT 1986 MIDWINTERS WITH TOP NON-SAILMAKER USING NORTH SAILS.

TO FIND OUT HOW YOU CAN GO FAST.CALL

Benz Faget
NORTH SAILS NEW ORLEANS
1716 Lake Avenue
Metairie, LA 70005
(504) 831-1775

Vince Brun
NORTH SAILS SAN DIEGO
1111 Anchorage Lane
San Diego, CA 92106
(619) 224-2424

FLEET BEAT

This new column will feature news from individuals and fleets around the country. Send in the interesting news from your fleet. Knowing others draws us closer together. Send your news of race results, season's championships, social events, new members; anything that will tell us about you. I can gather this information from your fleet newsletter too — if you'll put me on your mailing list!

So let's get with the beat, fleet! Ed.

Con Lancaster from Singing River Yacht Club in Pascagoula, MS tells us that the North is invading the South once again. It seems that Fleet 135's **Jerry Hartman** of Mahomet, IL has been travelling up and down the Gulf Coast recently to look for a cruising sailboat to keep there with Con for his many trips to the South. It seems that Jerry and his buddy **Kenny Johnson** are a little tired of Illinois snow and want to spend more time in the sunny, warm south. Con also tells us that the North's **Jeff Johnson** has been seen on many different occasions escorting Con's 1986 NAC crew **Virginia 'So-Fine' Stallworth** to regattas in Pascagoula, Pensacola and New Orleans. Con's worried that Scot notable **Greg Fisher** started the invasion when he stole **Larry Taggart's** Southern Belle crew, Charlotte, for his wife just over a year ago.

Con also reports that **Steve Bellows** has picked up nicely for **Chuck Barnes** as a representative for the Schurr loft. He has been sailing Scots very competitively and has been working hard on sail trim and sail design for the Schurr group. Just last month in the Pensacola Sports Association Regatta, he capsized his Scot and filled it to the gunnel with water to increase the waterline length. What Steve will do to experiment with boat speed is incredible!

Also down South, super-crew and all-around great class supporter, **Terry Dees** reports that 1984 NAC Challenger Champ **Dan Kolenich** recently purchased a new Scot. A doting father, he allowed his very young son Daniel to name the boat. Daniel's choice? 'Hunny-Bunny'. Dan, Daniel, Terry, and the venerable 'Granny' Dees (giving the standing orders) are shown aboard the H-B recently.

Moving West, Texas District Governor **Richard Wade**, who sails on White Rock Lake in Dallas, won his Corinthian Sailing Club's perpetual Maurice Martin Trophy

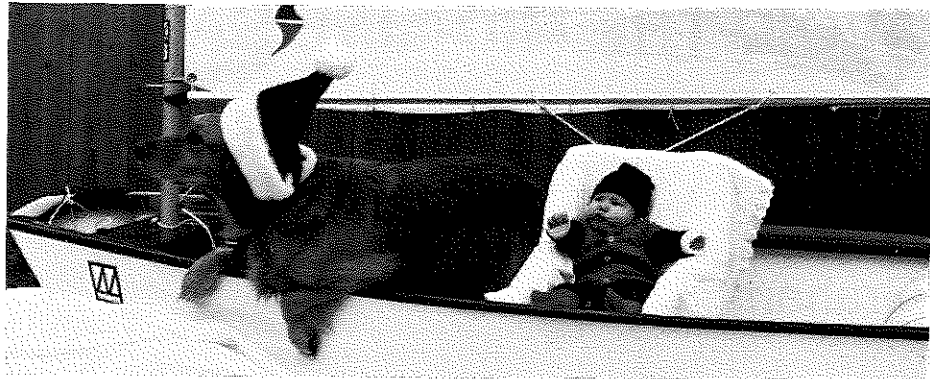

Martha Fisher and her Christmas Dog.

this year. This trophy is awarded annually to the best sailor in the club. Members from seven different classes participated in a five race round-robin series sailed in the locally-designed Corinthian Class keelboat. Other Scot sailors **Fred Tears** and **Roland Foerster** also did well finishing third and fifth. Richard is now a five-time winner of the trophy. Congratulations!

Fleet 23 is also proud of a recent USYRU accolade afforded their club, the CSC. The 1986 St. Petersburg Club Trophy was presented to the club for its excellence in race management in conducting the Hinman Team Race Championships in 1985 (which, by the way, Scot sailor and Area F Team Race Committee Member **Brad Davis** was instrumental in obtaining for the Club). This trophy is presented by USYRU annually in recognition of the club that demonstrates the highest degree of excellence in race management and for running the best regatta. Other Fleet 23 Scots sailors **Randy Robinson**, **Tom Shepard**, **Richard Wade**, and **Kelson Elam** were very important in the regatta's success and, thus, the recognition the trophy provides. Congratulations CSC and Fleet 23 Scots!

Further west, former Shore Sails employee, Scot sailor, and great party-animal, **Craig Leweck** sent your editor a letter recently. Seems Craig is working for Sobstad Sails in San Diego, CA and

is specializing in Snipe racing. He's been doing very well at it, too! But he asks me to tell you that he really enjoyed the Scot, the Class, and the racing and hopes to do some Scot sailing and sail development on the West Coast in the future.

Up North, **Ralph Manee** from Tom's River, NJ once again won the Barnegat Bay YRA's 73rd annual season. **Rich Kerdock** of Shore Acres placed second. Former Scot sailors **Bob and Dory Schneider** report that they miss the Scot but that it was a good teacher as they won the BBYRA's season championship for the very large Sanderling fleet (a local cat boat). Congratulations to all of you!

A little farther north we are happy to report that **Chuck Winans** (Fleet 57) and **Ken Fosdick** (Fleet 156) have been named editors of the Southern Massachusetts YRA's new publication, *SMYRA Sailing*. The inaugural issue looks great, guys! Keep up the good work.

Finally, moving over to the Midwest we find a picture of an adorable Cabbage Patch kid and her dog festooned for some Christmas sailing in Columbus, Ohio. What? What's that you say **Greg Fisher**? That's not a C-P doll? It's really your new daughter **Martha**? Well...she's sure a cutie!

That's all for now, folks. Send in your items so we can feature you, your fleet, or your club in a future Fleet Beat.



Hunny-Bunny and its crew.

AVOID THE MID-LINE SAG!

Ranges and Bearings

Graham Hall

Setting Your Range

When you need to get a good start in the middle of the line, or any time you are not starting right at the committee boat or the pin, you need to get a good 'range.' Here's what I do.

Say I have decided to start one-quarter of the way up the line from the leeward end. I proceed to a point just outboard of the starting line at the starboard end and sight down the line. In the background, behind the port end flag or boat will be — hopefully! — an object on the shoreline that I can use as a 'range.' It can be a tree, a house, a buoy, or just the way the land is outlined against the sky — a dip, a bulge or a different color shading.

Sometimes I develop a 'safety range' which is another object on shore that puts us definitely below the line. To get this range, do not sight directly down the line, but position yourself a couple of boat lengths astern of the committee boat at the starboard end.

As the start approaches, you are near the range but below it with either of your range points. You then monitor your progress right down to time zero where you start with full speed just on the range point.

In the last race of the 1985 NAC's at Riverside, Connecticut, we used Great Captain's Lighthouse, to the west of the line, as a range. We seemed to pop off the line and, except for Jerry Harman, felt we had earned the best start. We tacked to port, crossed the fleet, and led at the first mark.

Getting Your Bearings

Much of that year's NAC was sailed in light air and lots of current. The current itself wasn't running much more than a knot, but in light to even moderate wind, the current becomes a powerful factor and primary consideration. On almost any leg except the beat, a range is important to determine the effect of current on your course.

When heading to a reach mark or a leeward mark I would regularly request the crew to, "Get a range" or "Take a bearing" through the next mark. As long as that object on the shoreline through the mark did not move, we knew we were sailing on a straight line over the bottom (which is the shortest distance and should normally be the fastest way to get to the next mark). If the mark and the background were moving relative to each other, we would change course and trim the sail slightly to maintain the range and, thus, our fastest, 'straight-line' course.

This technique got us a good finish in

the second race of the finals where we actually determined early in the first leg (ostensibly a beat) that the current under our lee bow was actually setting us up past the mark. We bore off while others continued to sail close hauled. Because we knew they would actually end up overstanding the mark, we intentionally took their sterns in the very light air. Our use of a range bearing worked as we rounded the mark third, behind only local skippers David Beaney and Peter Beam who picked up what was happening before we did. As the three of us rounded the mark we saw the rest of the fleet setting spinnakers in order to get back down to the mark against the current.

Using a range bearing both on the starting line and on the off-wind legs of the course is a simple technique that can yield large dividends. So set your range, get your bearings, and go for a strategic victory!

The Graham Family's top-ten finish in the often tricky Long Island waters at the 1985 NAC could, in part, be attributed to these strategic ideas. Much of their continued racing success is also due to many years of Graham's racing experience and the teamwork of daughters Morgan and Whitney. And, oh yes, Cujo the wonder dog has often been heard barking strategy to skipper Graham, especially in important races such as the NAC.

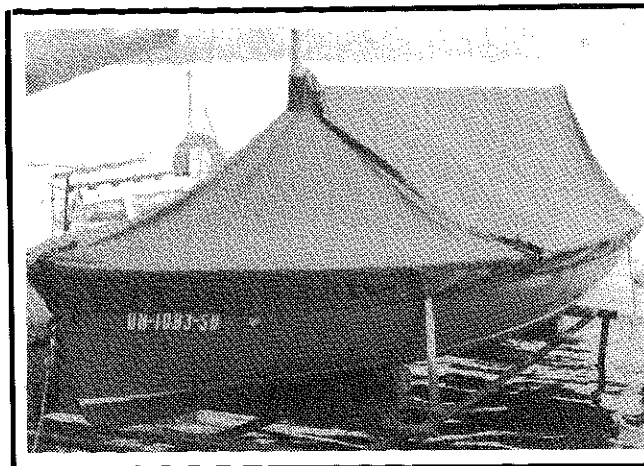

CUSTOM FITTED COVERS

**In stock ready to go
*Made by one design
sailors*

YACHTCRILLIC • CANVAS • URETHANE COATED NYLON

MOORING full deck over the boom (pictured)

COCKPIT boom tent that covers from mast to transom

TRAILING/MOORING use for trailing and/or fits with mast up for mooring

BOTTOM protects bottom & sides while trailing with nappac canvas flannel-lined

- **NOW • MONOGRAMMING** • Prevent loss by monogramming your name or boat number on your present or new cover.

EXCELLENT WORKMANSHIP • SATISFACTION GUARANTEED

For more information and samples: OR See your local dealer



The Sailors' Tailor

191 BELLECREST • BELLBROOK, OHIO 45305 • (513) 848-4016 • SANDY

The New Standard



- 1,2 Flying Scot North American Championships**
- 1,4 Flying Scot Midwinter Championships**
- 2,4 Flying Scot Junior Championships**
- 2,4 Flying Scot Challenger NA Championships**
- 1, 2, 4, 5 Flying Scot Canadian National Championships**
- 1 GYA Lipton Championships**

Shore Scot Sails are designed to perform equally well in a drifter on flat water as in a 20 mph blow in 3 foot seas. Since they've been tested and race-proven, you can be confident that when set up by the numbers suggested in our latest tuning guide, our sails will help you have your best season ever in 1987. Shore Sails are not only fast — but also easy to trim. They're not gimmick sails — but they do deliver the performance needed to win races. Ask any Shore customer. Give us a call and join the Shore team!

**WE WILL
HELP YOU
WIN.**



SHORE SAILS

**330 West Spring Street
Columbus, Ohio 43215
(614) 221-2410**

Other lofts in: Huntington, NY; Traverse City, MI; Aichi, Japan; St. Thomas, U.S. Virgin Islands; Newport, RI; Point Pleasant Beach, NJ; Winooski, VT; Annapolis, MD; Cleveland, OH; Houston, TX; Seattle, WA; Portland, ME.

Regatta Spotlight

Hot Scot & Michigan-Ontario Championship

Pat Barry

31 Scots sailed in the largest Scot regatta in Michigan since 1979 as they participated in the combined 'Hot Scot'-District Champion series on September 13-14, 1986. Combined with the large turnout, excellent competition, fair winds, and outstanding luau and roast, about the only unhappy participant this year was the pig!

The regatta was special not only because of its large turnout, but also because of the nature of the group attending. Three-time NAC Champ Tom Ehman, Jr. flew home to Portage Lake from Newport, Rhode Island to see his many old friends from host Fleet 20. Defending District Champion Pat Barry, also a 'local', sailed the event. Former M-O Champ Ray Flajole traveled over from his own nearby pond. Sailors from Indiana and Illinois also came north to sail. And only a business trip in Italy prevented FSSA President Jack Stewart from attending. Most important, however, was probably that the annual 'Hot Scot' drew from several other Michigan fleets for the first time in several years, boding well for a future increase in Scott regatta sailing in Michigan.

Just as he has so many times in the past, 'Tommie' Ehman conducted an on-the-water clinic in all elements of successful sailboat racing. Often behind District Champ Pat Barry, he would find some way to pull ahead and eventually won the series with four firsts. Ehman and Barry shared the trophy spotlight as



Ehman won the 'Hot Scot' and Barry the District Championship portions of the combined regatta. Both skippers were pushed hard by local club champion Dave Winston during the entire series.

Throughout the four races sailors faced the light-medium and very shifty winds that 'ponds' are famous for. Winning called for mostly conservative tactics with a prudent amount of gamble thrown in at the right time.

Perhaps the biggest draw to the event was the institution of the luau and pig roast this year. Shamelessly borrowed from Fleet 1, this pig roast served to generate the same enthusiasm as it has for several years on Cowan Lake. Thanks for the idea, Fleet 1! A huge circus tent was festooned with Hawaiian-like decorations and was inhabited by participants wearing all manner of 'genuine' Hawaiian

clothes and artifacts. The roast pig was done perfectly and highlighted the evening of food and drink that ended with a warm fall evening bonfire sing.

Fleet 20 cordially invites all Michigan and MidWestern sailors to this year's repeat event of the Hot Scot regatta on September 12-13 at Portage Lake. We promise that the only one disappointed with the regatta will, once again, be the guest of honor — the pig.

Tom Ehman, Jr., Jeff Cox 3, Pat Barry, Jr., Harold Gendelman 11, Dave Winston, Jane Winston 14, Dick Weaver, Dave Hertzberg 23, Craig Speck, Gretchen Speck 31, Ray Flajole, Carol Flajole 34, Forrest Rogers, Martin Ehman 35, Paul Maassen, Chris Maassen 37, Ib Bentzen-Bilkvist, Kirsten B-Bilkvist, Don Scherer 41, Jim Horein 48

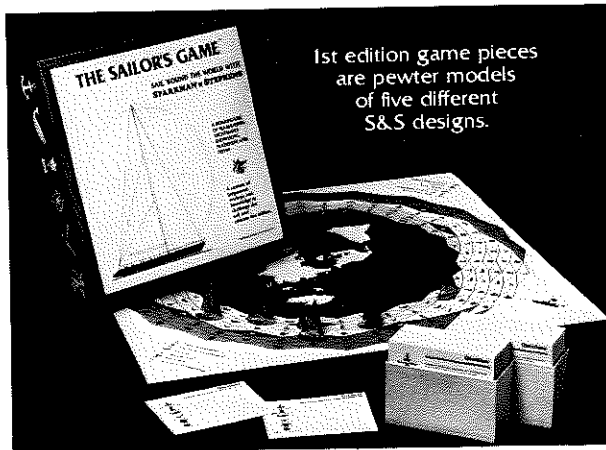

1st edition game pieces are pewter models of five different S&S designs.

THE SAILOR'S GAME™

BY SPARKMAN & STEPHENS
(Yacht designers of 8 America's Cup winners)

An exciting boardgame where old salts tackle questions on seamanship and navigation while new hands learn the ropes. Everyone becomes more familiar with the evening sky, safety, history, oceanography and traditions of the sea.

With 2,160 questions no one sits on deck with empty sails. Players command pewter yachts modeled on great Sparkman & Stephens designs.

This unique game concept encourages interaction among sailors with similar and different levels of experience.

\$40 plus \$2 postage. Visa/MC Order Toll Free
1-800-835-2246 ext. 61 or send check to:



THE SAILOR'S GAME
Box 20382 Cherokee Sta. NY 10028

The Perfect Gift for a Sailor.

WHEN THE SUN GOES DOWN, RAISE YOUR SAILS

Al Rees

I love night sailing. The sense of the strange and exotic, the sense of isolation, the challenge of finding place and destination with few clues, the challenge of trimming sails by the feel of the wind and the sound of the water, the beauty of the stars shining in a splendor that most landsmen rarely see — some of the finest rewards of sailing are unique to the night, or enhanced a hundred fold.

Sailing at night adds a dimension of freedom to sailing in the day. Not pressed to be back by sunset I can plan longer outings, follow farther the mood of the afternoon, and linger over coffee in a restaurant across the sound.

The water at night is a different world. It can be as black as a tar bucket. I have sailed where I could see downtown Seattle, ablaze with lights, just a few miles off, but I could not see my white mainsail. Unlighted objects are not at all visible. Logs in the water are notorious. You can be aground on a low shore before you see it. Boats are seen only by their own lights, or by obscuring lights behind them. Lights can be hard to interpret, and they can be lost against background lights on shore, and they can appear out of nowhere when they are startlingly close. I want running lights, and I want them legal and effective.

Some Flying Scot sailors avoid night sailing because they find it hard to get the proper lights. The choice of lights is not as simple as one might expect. Lights suitable for the Scot may be not stocked at local chandleries. Here I mean to review the rules as they apply to the Flying Scot and give some advice about lights now on the market.

I will not reprint here the Navigation Rules for I assume you have your own copy at hand. If not, get one. Copies are sold at most marine supply houses, and by the Government Printing Office. Be sure you have the current rules. Extensive revisions to the Inland Rules (toward agreement with the International Rules) were enacted in 1980 and became effective late in 1981. Several amendments to the International Rules became effective in 1983.

**“A collision at sea
can dampen your
whole evening.”
—Ancient sages.**

Applying the rules is complicated by a number of alternatives:

1. International or Inland Rules. You should know or find out which applies where you sail. The dividing lines are sometimes not obvious; for example, Puget Sound and Lakes Union, Washington, and Sammamish are under International Rules while other lakes in western Washington are under Inland Rules.
2. Sail or Power. Any sailboat with a motor in use (even if sails are in use also) is a power-driven vessel and is subject to their more demanding rules.
3. Size. The Flying Scot is under seven meters and has the right to use the simplest lights, but may use those required of larger boats, and you may well choose to do so.

LIGHTS UNDER SAIL

Both inland and International Rules are satisfied by “an electric torch or lighted lantern showing a white light which shall be exhibited in time to prevent collision.”

A flashlight used to light up your sails (not to blind the other skipper) when another boat approaches will show up your boat and its course and is all the law requires of you under sail. I use a three cell flashlight, which lights the sails brilliantly. Even if you have other lights, a flashlight on the sail can and should be used anytime you are in doubt that an approaching boat has seen you. The problem is that you must first see the other boat. No one is going to see you first. A fleet of small boats maneuvering in the dark and relying on flare-up lights is a prospect that would send me back to shore.

Sailing vessels over seven meters are required to display sidelights and a sternlight.

These terms are defined by law. Sidelights are red to port and green to starboard, each showing through an arc of

(continued on page 16)

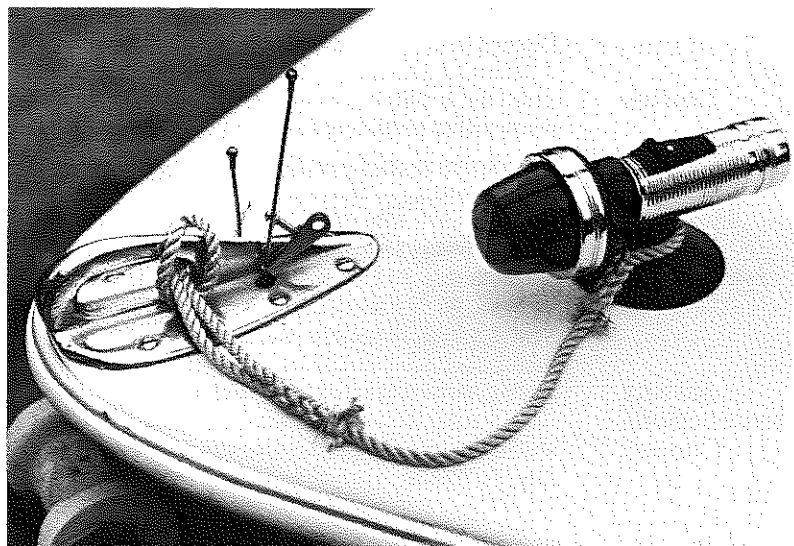

Sidelights combined in the Fulton No. 53 bow light. The suction cup has given good service but the safety lanyard gives peace of mind. Under power, put this directly forward of the all-round light.

Notice of Regatta

1987 FS Midwinter Championship

- Site** The 1987 Flying Scot Midwinter Championship will be held from March 23 through 27, on the waters of St. Andrews Bay. St. Andrews Bay Yacht Club of Panama City, Florida, is the host club and organizing authority.
- Rules** The regatta will be governed by the 1985-88 International Yacht Racing Rules, the prescriptions of the USYRU, the Class Rules of the FSSA, and by the Sailing Instructions.
- Eligibility** The competition shall be open to all FSSA registered sailors. Competitors must meet all ownership, class membership and yacht measurement requirements and must have paid all event fees.
- Schedule**
- | | | | | | |
|-----------|----------|---|----------|----------|---------------------------------------|
| Monday | March 23 | Registration and Sail Measurement
2 afternoon tune-up races | Thursday | March 26 | 1000 Race 4
1400 Race 5 |
| Tuesday | March 24 | Registration and Sail Measurement
1400 Race 1
1800 Oyster Bar | Friday | March 27 | 1000 Race 6
1800 Awards
Banquet |
| Wednesday | March 25 | 1000 Race 2
1400 Race 3
1800 Cocktail Party | | | |
- Sailors attending in previous years should take note of the changes in dates and schedule!
- Racing** The Midwinter Championship will consist of as many as six races. If all six races are run, the competitor's worst finish shall be discarded. Competitors shall place themselves in either the Championship or Challenger Division.
- Courses** Racing will be run on Olympic courses or variations thereof. Course length and sailing location will be determined based on sailing conditions.
- Scoring** The Low Point Scoring System, Appendix 5A, of IYRR, will be used.
- Prizes** Prizes will be awarded to at least the top seven finishers in the Championship Division and the top five finishers in the Challenger Division.
- Measurement** All sails will be inspected using the official FSSA specifications for sails. Mains and jibs that have a stamp from the 1986 N.A.C. will be waived from measurement. All hulls and equipment shall conform to FSSA specifications but will not be measured. All required and safety equipment shall be carried on board.
- General** A Midwinter Warm-Up Regatta will be held March 21-22 at Ft. Walton Beach, YC, approximately 50 miles west of St. Andrews Bay YC.
- Docking and mooring facilities at St. Andrews Bay YC will be available beginning Friday, March 28.
- Entries** Entry fee is \$40 if pre-registered by March 20. Add \$5 for regatta site registration. Checks should be made out to Midwinter Regatta Fund.
- Registrants should include their name, address, sail number and home fleet number.
- Housing** Some on-site tent and RV camping is available on a first come — first served basis. All motels are located within 15 minutes of St. ABYC. They are listed in order of proximity to the club.
Bayside Inn, 711 W. Beach Dr., Panama City, FL. 32401. (904) 763-4622. **Howard Johnson's**, 4601 W. Hwy. 98, Panama City, FL. 32401. (904) 785-0222. **Days Inn**, 4810 W. Hwy 98, Panama City, FL 32401, (904), 769-4831. **Ramada Inn**, 3001 W. 10th St., Panama City, FL 32401. (904) 785-0561.
- Sailing Instructions Contact** Sailing Instructions will be available at registration.
- Mail entry and check (payable to Midwinter Regatta Fund) to Mrs. Betty Smith, P.O. Box 406, Panama City, FL 32402.

THE FLEET'S IN

GREAT SCOT REGATTA

Fleet 118 hosted its annual Great Scot Regatta on October 11-12 at Lake Logan Martin near Birmingham, Alabama. The regatta was won by Mike Graham who started out confidently, but got more nervous as he slid down with each race. Robert Dunbar crewed for Mike. Close on their heels in 2nd place was Nelson Forbes with crew Steve Bellows from Shurr Sails. Wendell Hull and crew Bob Bamberg kept up the pressure by trailing 2nd by only ¼ point. Fourth place went to Bob Mewbourne with Robert Jenkins as crew. In the 5th position was Jim Johnson with Mark and Jody Johnson.

The first day consisted of very steady easterly winds (virtually 90 deg on the compass all day) at 10-15 mph. It was great until one got over to the leeward shore "protected" by tall pine trees from the wind. On the second day the winds diminished somewhat and became more southerly. As the wind shadows lengthened, the racing became more southerly. As the wind shadows lengthened, the racing became more subtle. A few strong protests dampened the spirits of the cocktail hour on the first day, but it was overall a good race. Fifteen boats participated in five races.

(Dave Whikehart, FS 3864)

Mike Graham, Robert Dunbar 15¾, Nelson Forbes, Steve Bellows 19½, Wendell Hull, Bob Bamberg 19¾, Bob Mewbourne, Robert Jenkins 20¾, Jim Johnson, Mark & Jody Johnson 33



Winners of the Great Scot Regatta: 1st row (l to r): Mike Graham, Nelson Forbes, Bob Mewbourne, Wendell Hull, Jim Johnson and Jody Johnson; 2nd row (l to r): Robert Dunbar, Steve Bellows, Robert Jenkins, Bob Bamberg and Mark Johnson.

Gulf District Championship

The 1986 Gulf District Championship was sailed by 16 crews on September 20-21, 1986. The four race series was sailed in nice weather with moderate breezes. Shifts of 10-25 degrees were frequent but predictable and the Race Committee did a great job in setting the course and moving weather marks throughout the series.

Back to back races were sailed each day on a Gold Cup course for each first race and an Olympic course for each second race each day. Racing was very close for the top ten boats and leads changed on each leg. Starts, too, were very competitive and the "I" flag caused a number of DNS finishes when sailors did not round one of the ends.

While many of the South's finest sailors were absent due to other commitments, it was, all in all, a very fun regatta with lots of competitive sailing and good parties.

Con Lancaster

Ken Kleinschrodt, Mobile, AL 4.5; Eldon Harvey, New Orleans, LA 7.75; Larry Taggart, New Orleans, LA 7.75; Eric Doyle, Pass Christian, MS, 10; Darren Cook, Ft. Walton Beach, FL, 13; Deven Hull, Pascagoula, MS, 16; Luther Carpenter, Mandeville, LA, 18; Mike Howell, New Orleans, LA, 18; Peter Christian, Metairie, LA, 20; Con Lancaster, Pascagoula, MS, 24.

West River Regatta

The West River Sail Club Annual Regatta was held on the West River at Galesville, Maryland on August 30-31, 1986. The Scot turnout was very good with 17 boats registering.

Light and shifty winds were the order of the day for Saturday. Race one featured a ninety degree shift on the first leg and was followed by shifts that produced two consecutive windward legs. Bob Neff, Carole VanWie and Frank Gibson played the shifts well to start the series 1-2-3.

Hoping to avoid such conditions, the RC set just a one-lap triangle for race two. The wind gods were not to be denied, however, and produced more light and shifty conditions. Richard Dirkhoff, John Barnes, and Bob Neff finished in that order thus scrambling the standings.

The final race started Sunday morning, again in light and shifty conditions. At the end of the first of two laps, the wind had dwindled leaving sailors to fight the drifting conditions and incoming tide. Even shortened, the race had to ultimately be abandoned when the three hour limit was passed.

Margaret Carson

Bob Neff 3.75, John Barnes 8, Frank Gibson 8, Laurus Newby 11, Richard Dirhoff 12.75 (continued on page 19)

The West Scot Corporation

1006 West Beardsley Pl.
Salt Lake City, Utah 84119

Builders of The Flying Scot®
in the *Western* United States

- Scots built to order
- Spare Parts Available
- Used Scots in Stock



Call: (801) 972-0350
or
973-6493

Mon-Fri: 7:30 a.m.-4:30 p.m.

Licensed by The Gordon Douglass Boat Co.

WHEN THE SUN

(continued from page 13)

10 points (112.5 degrees), from right ahead to abaft the beam. A sternlight is white and shows through an arc of 12 points (135 degrees) centered on directly astern.

Boats under 20 meters may combine their sidelights in one lantern on the centerline, and boats under 20 meters and under sail may combine their sidelights and their sternlight in one lantern at the masthead.

I use combined sidelights at the bow, an inexpensive unit like a flashlight with a red and green lens, Fulton Industries No. 53 bowlight.

I will refer here to several Fulton products. They are inexpensive and use two D cells for power. If not at your chandlery their products can be bought by mail from Fulton Industries Inc., P. O. Box 377, Wauseon, Ohio 43567, telephone (419) 335-3015. Their bulbs are a special type and you should buy spares from Fulton. Battery life in my experience has been reasonable and only once have I had them fail in use, though of course I carry spares. I now use only alkaline batteries;

their shelf life as well as their service life is much longer than that of carbon zinc batteries. I am not aware of other brands of lights using flashlight cells for power.

There are an abundance of lights from several makers using 12 volt power from the boat's electrical system. The system may be nothing more than a battery and wires, but to me even that seems a needless complication. Twelve volt batteries are much more expensive than D cells. I would still want a spare battery. And even among 12 volt equipment there seems to be no good sternlight for the Flying Scot. All I have seen are obstructed by the rudder and tiller.

Fulton's No. 53 bowlight sticks to the foredeck with a suction cup; I use also a safety lanyard to the bow eye. The light is at a good height, above the bow eye and below the jib, but the suction cup cannot be put directly on the center line of the Scot because of the ridge in the deck. It still is quite satisfactory when the boat is level. When the Scot is heeled the light is obstructed by the jib to leeward and perhaps the deck to windward. Moving the light about can avoid the obstruction on one side only.



The all-round light in its mounting block on the transom. This is an older model; the current Fulton lights have a larger and quite different lens.

(continued on page 17)

GO FAST Super Schreck Sails

You can't beat 46 years of sailmaking and 58 years of sailing. Our sails have won it all in Scots. In other classes they have won in Olympics, Worlds, North Americans, Districts and many others.

Best for Less, Instant Scot Sails

**Our prices are fair
and our delivery is prompt.**

Get the edge over your competition now with your own set of Super Schreck Sails. Call about our Special Yacht Fleet discounts.

Paul Schreck & Co. • S. Scenic Drive • Lillian, Ala. 36549 • 205/962-2570

WHEN THE SUN

(continued from page 16)

Larger sailboats avoid obstructions by carrying their sidelights on a bow pulpit or at the masthead. Most Scot sailors will find those lights and their power supply far too expensive.

Nearly all my night sailing has been in light winds. The winds often weaken at sunset, I am much more conservative in my sailing at night, and when the wind does rise there are fewer unlighted boats. These things considered, I think the deck mounted bow light is acceptable.

There seems to be no sternlight on the market suitable for the Flying Scot under sail (an all-round light is not really a sternlight no matter where located). Any light at deck level or lower will be obstructed by the rudder and tiller. Any light much higher will foul the mainsheet.

Fulton Industries makes an all-round white light on a suction cup (their No. 50) about eight or nine inches high. I have not tried it but it might work well if fitted black tape or some other simple mask made very carefully to restrict the light to the proper angle, 135 degrees centered astern.

The all-round lights used under power (see below), on a pole at the transom, don't adapt well as sternlights for a Scot under sail. They are too likely to hook the mainsheet.

Under sail I use the Fulton bow light and a flare-up light when vessels approach from astern. This is better than the flare-up light alone, at least over 225 degrees of the horizon forward.

LIGHTS UNDER POWER

Under the Inland Rules the simplest lights permitted to the smallest power vessels, under seven meters, are an all-round white light and sidelights. The International Rules permit an all-round white light as the only light on vessels under seven meters and seven knots; sidelights are still to be exhibited "if practicable."

Larger power vessels under either rules exhibit one or two masthead lights and a sternlight. A masthead light is a 20 point (225 degree) white light centered forward; a sternlight is 12 points (135 degrees) centered aft, so between them they complete the circle.

I can see no case for omitting the sidelights. The Fulton bow light (above) is inexpensive and, under power, not likely to be obstructed. An all-round light alone tells nothing of your course. Most mariners will take it for a sternlight and assume you are headed away. Would you really want that?

The all-round light is a problem. It is difficult to locate satisfactorily on sailboats under power. There are too many obstructions, especially when motoring with the sails up. The best position is the masthead. An alternative used on larger boats is a sternlight on the after rail and a masthead light, often on the forward edge of the mast above the jib. Both alternatives keep the light out of the eyes of the crew.

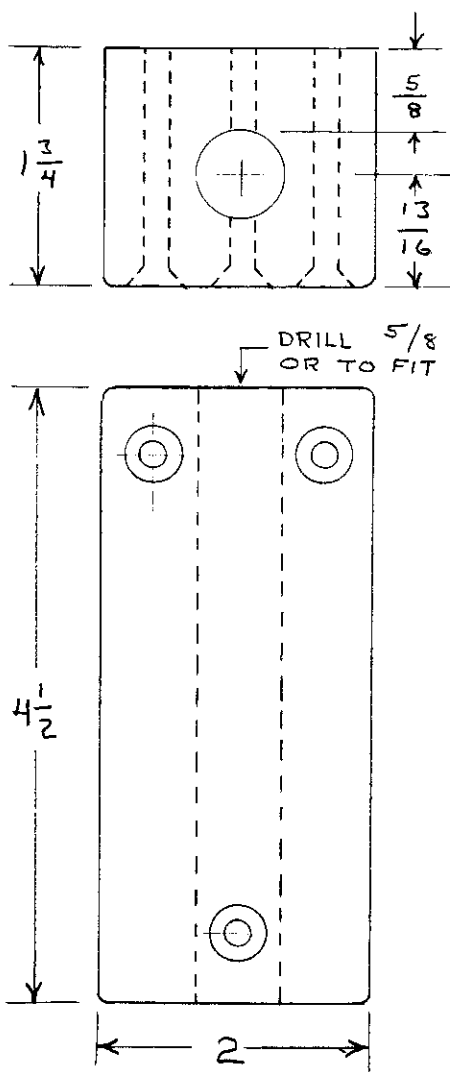

Mounting block for all-round light. Made from hardwood and attached to transom on right, well clear of the rudder an inch or two below the rub rail. Resist the temptation to make this from 1 1/2 inch stock. Drill through 5/8 or to fit loosely your light's pole. Drill through 3/16 three places and countersink for #10 machine screws. Check the distance your rub rail overhangs your transom and adjust dimensions if necessary. The pole should be a loose fit in the hole in the block and should be retained by friction against the rub rail. You may need a pad of soft tubing or tape between the pole and the rail.

Note that combined sidelights at the masthead should not be used in a sailboat under power. Sidelights forward are required by law. There is a reason: if the sidelights were at the masthead, they could not be forward of the (white) masthead light, nor forward of an all-round light unless it be aft and low. The intent of the law is that you should be able to judge the course of a boat about to run you down. The sidelights are to form a range with a white light above and astern of them.

Small motorboats always put their all-round lights on a pole at the stern. There, it does not blind the crew, so long as they look forward. The light is at best a menace to night vision, so the farther aft, the better. The pole is to let the light be seen from forward and not obstructed by the crew.

Various all-round lights on removable poles to be mounted at the transom are on the market. Most are for 12 volt electrical systems.

I use Fulton's No. 48 two cell all-round light on a pole, 25 inches overall. This came with a C clamp on the end of the pole. I sawed off the clamp end and made a wooden block, with a hole to fit the pole, and bolted the block to my transom (see photo). The light can be attached or removed very quickly. The varnished mahogany block is inoffensive, and serves a second purpose. When I sail in Canada I put a flagpole in the block.

If you intend to motor at night you should mount an all-round light in such a block or some other sturdy support. You may find it practical to attach the light to your boom crutch. The drawing gives dimensions for a block I recommended somewhat bigger than that I have. It is important to attach the light as rigidly as you can. Vibration from the outboard can shake the bulb loose. Fulton's No. 49 would now be my choice for the light; it omits the useless C clamp. It has a fastener, through which the pole slides, intended as a mounting block but quite inadequate.

The light should be as high as possible to shine over the crew's heads, but not so high as to be obstructed by the boom and sail. The Fulton No. 49 mounted in the block will put the light about 16 or 17 inches above the transom. It will not be seen by some boats forward. Two feet above the transom would be better. Fulton sells a kit of two extension poles, their No. EK-4849, which I have not tried, for just this purpose.

(continued on page 21)

Notice of Regatta

North American Championship

Site

The 1987 Flying Scot North American Championship will be held from July 20 through 24, 1987, on the waters of Lake Carlyle. Fleet 83 and the Carlyle Sailing Association of Carlyle, Illinois, is the host club and organizing authority.

Carlyle Sailing Association is located in Hazlet State Park on Lake Carlyle, about 50 miles east of St. Louis, Missouri. Lake Carlyle is in the fairly flat terrain of Southern Illinois. It is 8 miles long by 3 miles wide, making it possible to set a two mile windward leg in any direction and to swing the race course significantly about any mark.

Sailing Conditions

The sailing area is generally in view of the CSA grounds. In late July the prevailing winds are southerly system winds in the range of 5-15 mph. Because the average depth of the lake is only 11 feet, some chop can be expected.

Facilities

CSA has paved boat parking for over 300 boats, with tie-downs, and ample automobile parking as well. There are 3 one-ton cranes, a large paved launching ramp, and 1400 feet of floating docks for launching and between-race mooring.

Site amenities include picnic pavilions, rest rooms with showers, and a club house. There is also a full time harbormaster in residence.

No pets are allowed on CSA grounds — a vigorously enforced CSA rule.

Housing

Motels. The following motels should provide appropriate housing. They are rank-ordered based upon cost, proximity, condition, and amenities.

Best Western, Greenville. 20 min. (618) 664-3030.

HiDeHo, Carlyle. 15 min. (618) 594-2474.

Knotty Pines, Breeze. 25 min. (618) 526-4556.

Holiday Inn, Salem. 30 min. (618) 548-4212.

All units have restaurants and are reasonably priced. Contact motels directly.

Camping. Hazlet State Park is adjacent to CSA and is one of the best anywhere. Sites are reasonable, clean, and offer hot showers as well as a convenience store.

No reservations are taken; first come, first served. A large park, you may wish to camp near the suggested site. If you like solitude, we suggest camping elsewhere in the park.

Maps will be sent to pre-registrants.

Club Background

The members of Fleet 38 and CSA have extensive experience in hosting major regattas and they have a sailing facility that can comfortably handle over 200 contestants in a single event. The CSA hosted the 1979 FS NAC and recently hosted the 1986 Midwestern District Championship. Since its founding in 1971, CSA has hosted at least one national championship regatta each year. In addition, CSA hosted the 1976 Championship of Champions and the 1977 Yachting Magazine One-of-a-Kind Regatta.

Chairmen

The regatta will be co-chaired by Jim Harris and Bernie Knight. Contact Bernie at 15999 Quiet Oak Road, St. Louis, MO 63017. (314) 532-9410.

Registration, Social, and Schedule information in May/June issue of *Scots n' Water*.

FLEET'S IN

(continued from page 15)

Cowan Lake Pig Roast

Although 42 skippers and crews arrived at Cowan Lake for the 1986 Pig Roast Regatta, the stronger fall winds never did show up. All four races in the two day event were contested in 0-5 knots of very shifty wind. In one race the frustrated skippers were subjected to at least ten minutes of wind from each of the four points of the compass! The conditions made for extremely close competition with many large changes in position and in all but one race at least half a dozen boats had a strong chance to win on the last leg of the course. Fleet 6 Champion Dick Gregory edged out Fleet 37 Champion Jack Huling for the title while 1986 Sears Cup Champion Jeff Irvine led the Fleet 1 locals with a third place finish.

The seventh consecutive record turnout required splitting the fleet into two divisions for the first time. Fittingly, the 19 boat challenger group was immediately named the 'Oink' division. Bob Sumerfeld from Cave Run Lake, Kentucky, won three of the four 'oinkers' but just narrowly won the division due to a low finish in his only non-winning race. Julian Magnus, Jerry Saul, Same Noe, and Robbie Freemont, all of the host fleet, finished in 2-5th places respectively.



Mark Rounding at the "Pig Roast."

Another famous Fleet 1 Pig Roast and the usual late night cavorting, led by the infamous Fleet 37 Traveling Road Show from Columbus, Ohio, highlighted the social festivities.

Based on the large turnout, Fleet 1 organizers are confident of a very large turnout for the upcoming special 30th Anniversary Celebration here June 27-28. Mark your calendar now to attend perhaps the largest gathering of Flying Scots in our history!

Sandy Eustis

Dick Gregory 12.5, Jack Huling 14.5, Jeff Irvine 21, Jack Leipper 26, Jack Rudy 32, John Eilers 34, J. C. Dye 35, Bob Cornish 38, Peter Salmon-Cox 40, Lynn Goodwin 41.

SCOTS N' WATER

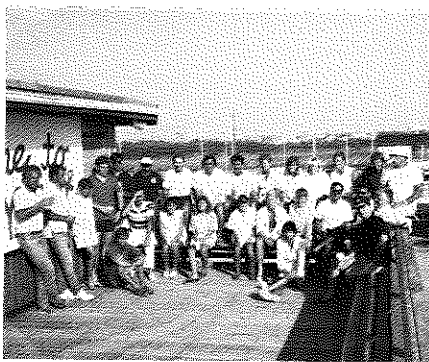

Lancaster Cup winners gather at Singing River YC.

Lancaster Cup

The fourth annual Lancaster Cup was held at Singing River Yacht Club, Pascagoula, Mississippi on September 6-7, 1986. Hosted by Fleet 92, this event is sailed by Gulf sailors under the age of 19. This year's five race series (with one throw out) featured ten very competitive youth skippers and their crews. Eldon Harvey of New Orleans, Louisiana bested the fleet with four 1sts and a 2nd.

The Lancaster 'Last to Round' race is a unique feature to this series. In one of the standard Gold Cup courses points are awarded for the number of boats a skipper beats to each mark and no boats can round any mark until the last boat rounds first. This unique race comes from a training method used in the club's Junior sailing program and the racers like it because it produces close racing and the development of good tactics in the jockeying for position. The spectators, too, enjoy watching how the sailors come out of each mark.

Con Lancaster

Eldon Harvey, New Orleans, LA 3; Deven Hull, Pascagoula, MS 8.75; Eric Doyle, Pass Christian, MS 14; Mike Kane, Pensacola, FL 15; Billy Ross, Mandeville, LA 16; Charlie Dellinger, Biloxi, MS 20; Page Murphy, Bay St. Louis, MS 23; John Faulk, Gulfport, MS 28; Beth Beery, Pascagoula, MS 33; Phil Everett, Pascagoula, MS 35.



Happy "Whiskey Sour" winners. Was it the trophies, or something they drank?

Whiskey Sour Regatta

In one of the most competitive regattas in recent memory, Ohio aces Rick and Jo Baugher eked out a narrow victory in the Fleet 80 Whiskey Sour Regatta sailed on September 20-21 at Lake Arthur, near Pittsburgh, Pennsylvania.

Going into the last race of the five-race, no-throw-out, series five boats were within 2 points of each other! The leaders were last year's winner Mike Cullen and Class President Jack Stewart. Breathing down their necks were the Baughers and Deep Creek lake sailors Peter Salmon-Cox and Dick Gregory. Baugher and Salmon-Cox won the start at the heavily-favored boat end and finished 1,3 which was good enough to win the top two prizes. Early leaders Cullen and Stewart finished 6,7 and dropped to a still-respectable series third and fourth. Rounding out the top five was Jack Orr whose finish made the long drive home to Connecticut more pleasant. The competition throughout the series was so tight that the five races were won by four different boats.

Like participants all fall, these 25 boats and crews faced light, 5-10 mph winds. The results showed that 'local knowledge' was not a factor again this year.

The non-racing highlight of the weekend was the Saturday night Steak Fry. Local hosts Fleet 80 provided a variety of delicious hors d'oeuvres. Fleet Champ Jim Starr supplied gallons of whiskey sours and showed his culinary expertise on the grill, cooking 80 steaks!

The 1986 regatta was the best-attended ever and firmly established Lake Arthur as the 'place to be' for Ohio District sailors on the third week of September each year. Plan to be here this year!

Dan Goldberg

Rick Baugher 22.5, Peter Salmon-Cox 25, Mike Cullen 26, Jack Stewart 27, Jack Orr 27.75, Dick Gregory 29.75, Jack Leipper 31.75, Dave Caldwell 49, Dan Goldberg 51, C. Cullen 63

(continued on page 20)

FLEET'S IN

(continued from page 19)

"Open House" & Texas District Championships

Almost two decades ago the most active sailing class and fleet, FS Fleet 23, on White Rock Lake, Dallas, Texas, decided to hold a regatta to be sailed in Scots only, but open to any sailor with Fleet or association membership not being a requirement. Thus started what became known as the 'Open House', a regatta sailed in September at Corinthian Sail Club with a championship and challenger division, but always with a friendly group of sailors. 24 boats sailed in the event on September 20-21, 1986. Nine guest skippers from the M-20 Scow, Rebel and Corinthian keel boats classes participated in Scots loaned by other Fleet 23 members.

For active FSSA members, this regatta also served as the District Championship. Normally the Districts are not combined with the Open House, but this year the Districts, also hosted by Fleet 23, were rained out in May and rescheduled for the Open House.

Both divisions were started together, but scored separately. Unlike the earlier cancelled regatta, the weather was perfect: warm, sunny, 5-10 mph winds, and just shifty enough to make the races interesting, though the narrow lake (2 miles by 1/2 mile wide) is known for being shifty.

Richard 'Bullet' Wade seemed to be sluggish and struggled in the early part of the first two races, but as is his custom, managed to work his way through the fleet by taking firsts in all three races. With the win, Richard and crew Jennifer Wade and Melodie Hammer repeated as Texas District Champion.

After the end of Saturday's races, five skippers were in the running for second place: Bill Leonard, Mike Uyeda, Roz Bowen, Brad Davis, and Roland Foerster. Leonard, a guest skipper from the M-20 fleet eventually finished second overall.

In the challenger division Skip Waller and Pat Manicchia finished 1-2. Both of these sailors were from the Corinthian Class keel boat fleet.

The 'Open House' doesn't forget that good hosts feed their guests. On Saturday evening the CSC dock supports skippers who consume 12 oz. steaks grilled



Texas District Participants

to order as they overlook White Rock Lake. On Sunday morning skippers are lured back to the race course with Ed and Marian Lockey's biscuits and gravy. This part of the regatta is so traditional that Ed is not allowed to sail unless he brings the food!

The thrill of winning a trophy is always the goal for any skipper, but Open House is intended to be an exciting experience for non-Scot owners as well as a learning experience for new Scot owners. A total of four new owners sailed in this year's regatta and one of the guest skippers soon after became a proud new Scot owner, as well. Thanks to Brad Davis the skippers were able to view their performance on video-cassette during Saturday's Happy Hour. And thanks to a local Dallas TV station, we were able to see ourselves again during the evening's newscast. Seeing 24 Scots under full spinnaker in 10 mph winds with the Dallas skyline in the background was a thrill and a worthy 'trophy' for all the participants.

Around CSC our slogan to sailors from other classes is to "find a Scot and join us at the 'Open House'!" But thanks to the generosity of many gracious Fleet 23 members, that's not too difficult. And with help from others, both in and out of the Scot fleet, this regatta is always a big success. Our goal is to have 35 boats next year. Come down and join us in Texas!

Roland and Jeffrey Foerster

Championship Division

R. Wade 2.75, B. Leonard 11, R. Bowen 13, M. Uyeda 14, B. Davis 16, R. Foerster 17, B. Gough 20

Challenger Division

S. Waller 38, P. Manicchia 40, P. Michaels 45, R. Voges 46, A. Tuell 48

New England District Championships

The New England District Championships for Flying Scots was hosted by Duxbury Yacht Club on August 8-10, 1986. This event attracted 36 boats, perhaps the largest 3-man boat event held in New England this year. All the fleets in the District were represented. Ned Lawson from Duxbury YC and his crew Derek McDonald handled the wide variety of sailing conditions to perfection in capturing this event. Ned also was awarded the SMYRA Flying Scot Championship bowl which is given only to a skipper from a SMYRA club. Ned's record of 4 first place finishes in the four race series was exceptional considering the size of the fleet, the level of competition, and the variety of conditions.

On the first day only one race was held due to the constant threat of violent thunderstorms. The race developed into a three way battle for first between Terry Kelleher, Jack Clark, and Lawson. Lawson took the lead on the second beat and won the first of his four races.

Saturday produced some more consistent weather with winds of 8-15 knots. Terry Kelleher sailed into a healthy lead only to see it evaporate on the last leg of the course after he experienced some spinnaker problems. Again, Lawson took the lead at the end winning in the last 100 yards. The second race of the day was run in similar conditions and, again, Lawson won. Note that 'local knowledge' does not always pay off as Terry Kelleher sailed himself out of contention by sailing to the wrong mark.

Sunday's final race was sailed in a light wind, giving the series a wide variety of conditions. What didn't change was Ned Lawson's winning streak.

Series runner-up was Jack Clark who had to fight back from 20th to 6th in the race in order to maintain the position. The Clark boat was a father/son team with District Governor John Clark relinquishing his usual skipper position to his father.

One of the highlights of the event was a very successful party on Saturday night with over one hundred people showing up for cocktails and dinner. It was a good opportunity for the competitors to meet each other and share information about themselves, their boats, and the racing.

John Clark

New Lawson 3, Jack Clark 14, Gary Powell 18, James Cavanaugh 20, Carl Smit 28, Will Stearns 38, Terry Kelleher 41, Chuck Post 51, Bill Bazely 54, Peter Crawley 54. (continued on page 21)

FLEET'S IN (continued from page 20)

Citrus Bowl Regatta

Eleven Scots attended this regatta with over 300 total boats participating. Three courses were set on Lake Monroe in Central Florida. The 20 knot wind and two foot rollers kept some boats off the lake on Saturday, but it was warm and sunny and we were rewarded with some 'screaming reaches.' While none of the Scots capsized, boats from many other divisions were not so lucky.

Saturday night featured an all-you-can-eat shrimp dinner.

An early morning rain cleared out in time to produce a beautiful, though still heavy-wind, day. In all, 5 races were sailed during the series.

Jeff Spencer, E. H. Carpenter, Gus Chennells, Mike Kiely, Jeff Hicks

Cajun Country Championship

The fourth annual FSSA Cajun Country Championship was run at Lake Arthur YC's Gumbo Regatta in October, 1986. FSSA Fleet 153 sponsored the trophy.

The series finishers were rather consistent with winner Al Reed being aided by both excellent crew — Luther and Marie Carpenter — and new sails. A tough combination to beat!

Al Reed

Al Reed 3.5, Jeff Hooper 8, Peter Vogel 9, Steve Luthy 11

WHEN THE SUN

(continued from page 17)

The extension kit raises the intriguing prospect of mounting the light low for sail (on its own pole cut short, and with a mask) so that it avoids the mainsheet, and mounting it high for power (on an extension pole). If you try such a thing, take care with your geometry. You don't want to leave an angle where you won't be seen at all.

LIGHTS AT ANCHOR

Boats under seven meters are excused under both rules from showing an anchor light, provided they are "not in or near a narrow channel, fairway, anchorage, or where other vessels normally navigate." This phrase seems to leave it often to the skipper's judgement whether to show an anchor light. If used, it is to be an all-round white light located where it can best be seen.

Twice I have spent the night at anchor where I thought a light was called for. I have tied the all-round light used under power loosely to the forestay and hoisted it, not too near the mast, with the jib halyard. A light line was attached as a downhaul. New alkaline batteries were used and the light was still shining in the morning. The light must be upright to be visible all around and to not shine on the deck, where its glare would be obnox-

ious. If you are planning an all night outing, consider making a wire hanger, attaching a weight to the pole, or making a shade.

CONCLUSION

For sailing only you need a bright flashlight, and sidelights at the bow are good seamanship. A sternlight is also desirable but would have to be adapted. Under power an all-round light (or a more expensive alternative) is required, and sidelights are required under Inland Rules and good seamanship anywhere. You will need to make an attachment for the all-round light. The all-round light can be hoisted as an anchor light.

Know your waters and sail with caution. Consider the possibility of night and fog. Plan your courses. Take a chart and take warm clothing and hot drinks. Take a small dim flashlight or other means of lighting your compass and chart. A five-cell flashlight is a powerful spotlight for locating buoys and going into dark harbors.

Al Reed is part of a very spirited group of Scot sailors who ply the beautiful waters near Seattle, Washington. While their fleet has regular races, they highlight fun and family activities which culminate in their annual week-long cruise in some part of the Puget Sound. Al is a regular at both the racing and cruising events and provides strong support to the fleet's many and varied activities. We look forward to future stories by Al recounting the various fleet cruises.

ACRYLIC FLYING SCOT COVERS

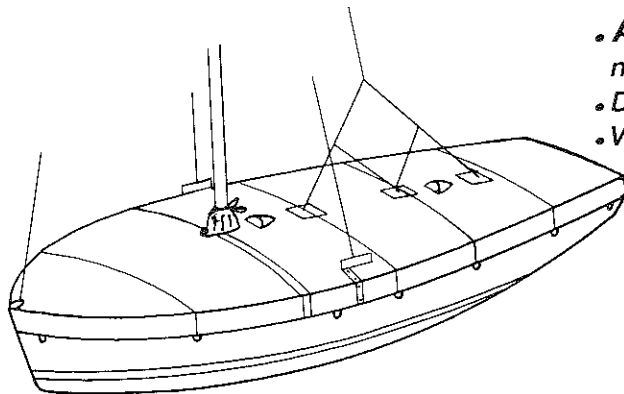

- Acrylic, an attractive, handsome material, will not rot, mildew or shrink—Lasts TWICE as LONG
- Delrin zipper covered by flap—velcro secured
- Velcro enclosures for side stays
- Very light & easy to handle
- Never stiff or brittle
- Ventilation by netted opening w/ hood
- White & Blue — FAST DELIVERY!
- Other Colors

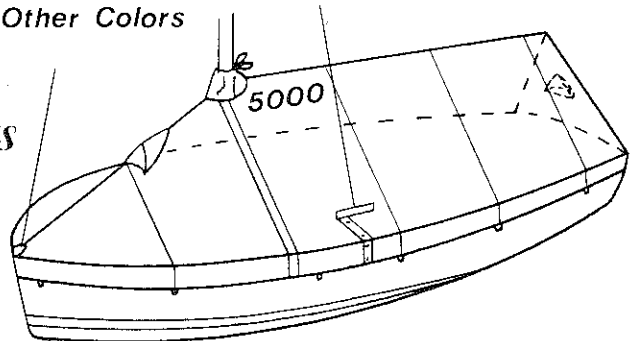

FLYING SCOT	White	Blue	Other Colors
Flat 6" Skirt	210 ⁰⁰	220 ⁰⁰	231 ⁰⁰
Flat Full Side	275 ⁰⁰	289 ⁰⁰	303 ⁰⁰
Tent 6" Skirt	249 ⁰⁰	265 ⁰⁰	278 ⁰⁰
Tent Full Side	299 ⁰⁰	315 ⁰⁰	330 ⁰⁰
Sail # Installed		25 ⁰⁰	

CHRIS ROOKE Check in advance - no UPS
901-744-8500 MC, Visa, AmEx - add UPS

ROOKE SAILS
1744 Prescott South
Memphis, Tenn 38111



THE STARTING LINE

Regatta Organizers: Please take note of other major FSSA events and make the appropriate effort to avoid a scheduling conflict with them.

We would like to help you publicize your event! Please send, or call, your regatta notices to the Editor in a timely manner!

1987 MidWinter Championship

March 23-27. See Notice of Regatta in this issue.

30th Anniversary Celebration

June 27-28. See information in this issue.

1987 North American Championship

July 20-24. See Notice of Regatta in this issue.

Carolinas District

April 25-26 Spring Invitational. Lake Norman YC, Lake Norman, NC. Contact Len McLaughlin, Box 6113, Spartanburg, SC 29304. (803) 579-2689.

May 2-3. 14th Annual Great 48 Regatta. Lake Norman YC, Lake Norman, NC (Note corrected date from Jan. issue!) This fine event attracts over 30 of the top sailors in the country each year. Contact Hal Walker if you are interested in leaving your boat here on the way home from the MidWinters at Box 847, Davidson, NC 28036 (704) 892-1276. Contact Len McLaughlin for details.

Capitol District

April 25 Lake of the Woods 6th Annual Invitational Regatta. Wilderness, VA. Hosted by Fleet 160. 3 races, picnic/dinner, and awards. Contact John Beery, Box 305 L.O.W., Locust Grove, VA 22508. (703) 972-7411.

Gulf District

May 16-17 Iron Man Regatta. Birmingham Sailing Club, Lake Logan Martin, Alabama. Contact Dave Whitehart, 1137 Mt. Oaks Dr., Hoover, AL 35226. (205) 822-0740.

Michigan-Ontario District

June 13-14 District Championship. Gull Lake, Kalamazoo, MI. Come sail this 5 race series on the sparkling waters of Gull Lake. Contact John Kittridge, 3801 Wind-ing Way, Kalamazoo, MI 49007. (616) 382-4713.

Sept. 19-20 'Hot Scot' Regatta. Portage Lake, Pinckney, MI. In 1986 this event attracted 31 Scots from Michigan, Ohio, Indiana, and Wisconsin. A fantastic Hawaiian Luau and Pig Roast will be repeated. Contact Pat Barry, 34090 Parkdale, Livonia, MI 48150 (313) 427-0797.

Midwestern District

TBA. District Championship. Lake Michigan, Wilmette, IL. Contact Dennis Dugan, 243 Linden, Wilmette, IL 60091. (312) 256-8786.

Sept 26-28 'Glow in the Dark'. Clinton Lake, Champaign, Urbana, IL.

May 16 Spring Regatta. Delavan Lake Yacht Club, Dalavan Lake, Wisconsin. Contact Tony Minniti, 116 West St. Charles Rd., Villa Park, IL. 60181. (312) 832-5458.

New England District

July 24-26 District Championship. Dux-bury Yacht Club. Contact District Governor John Clark, Jr.

NY Lakes District

July 18-19 District Championship. 4th Lake, Old Forge, NY. Contact Butch Hartsig, 116 West Ave., Fairport, NY 14450. (716) 377-8331.

Ohio District

May 16-17 Buckeye Regatta. Hoover Reservoir, Columbus, OH. 3 races. Over 40 boats raced last year! Contact Jay Huling, 877 Prince William Lane, Westerville, OH 43081. (614) 882-4591.

June 6-7 Berlin Invitational. Berlin Lake, North Benton, OH. Over 30 boats sailed last year. Free camping on the site. Meals at club are reasonably priced. Contact Bob Skillman, 8501 Black Oak Dr., Warren, OH 44484. (216) 856-4541. Note corrected date from Jan/Feb issue!

June 27-28 District Championship. To be held concurrently with the 30th Anniversary Celebration. Cowan Lake, OH. Contact Governor Chuck Hoffman.

July 11-12 Cleveland YC. Lake Erie. Contact Paul Nickerson, 12664 Webster Rd, Strongsville, OH 44136. (216) 238-9378.

Sept 26-27 Whiskey Sour Regatta. Mo-raine State Park, Pittsburgh, PA. Fleet 80 hosts 5 race series. Saturday night steak fry and whiskey sours. Contact Dan Goldberg, 1100 Penn Center Blvd, #515, Pittsburgh, PA 15234. (412) 823-8579.

Texas District

May 16-17 District Championship. Site to be determined. Contact Governor Richard Wade.

June 6-7 Fort Worth Boat Club Annual Regatta. Contact Richard Wade.

July 4-5 Austin YC Governor's Cup. Contact Richard Wade.

Sept 19-20 'Open House' Regatta, Dallas. Contact Richard Wade.

Oct 31-Nov. 1 'Wurstfest' Regatta. Contact Richard Wade.

USYRU Events

October Champion of Champions. Southern Yacht Club. The Class that started this event celebrates its 30th Anniversary by being the boat of choice at this year's event Contact VP Larry Taggart for more information.

Sailing Seminars

May 31-June 1 T-J Sales Company, Portage Lake, Pinckney, MI. (Home to Fleet 20.) Sailors from around the country have attended this successful event for many years. All instructors are District or National Champions in Sunfish, Laser, Rebel, Interlake and Flying Scots. District Champion Pat Barry works closely with the Scots sailors attending. Contact Tom Ehman, 8930 Dexter-Pinckney Road, Pinckney, MI. 48169. (313) 426-4155.

Caveat Emptor

Submissions for "Caveat Emptor" must be 50 words or less. A \$10.00 fee is charged per insertion. Advertisements are due two months prior to publication date. Contact: FSSA, Sandra Babson, 3008 Millwood Ave., Columbia, S.C. 29205 (803) 252-5646.

Sailing Seminar — Improve your racing! Have a seminar at your lake! 5-time FS District Champion/NAC Champion crew can run a custom-tailored seminar at your site. From an evening to a full weekend. On shore/on water. Video equipment. Many years experience running seminars for all level sailors. Contact Pat Barry, 34090 Parkdale, Livonia, MI 48150. (313) 427-0797.

Wanted To Buy — Used sails and any parts for Flying Scots. Write J. Percell Jones, Camp Morehead, Morehead City, NC 28557 or call (919) 726-3960.

Trailer, Sterling Tilt — 1971. Needs work but is usable. \$75.00. Frank F. Harding, P.O. Box 274, Brookside, NJ 07926. Days (201) 884-2627.

FS 478 — Customflex, White deck/white hull with blue stripe. Two suits of sails, spinnaker, boom tent, lifting bridle. Gator tilt trailer, anchor, outboard mount, 3 hp Johnson and other misc. Joe Fishburn, 2514 NW 4th Avenue. Rochester, MN 55901, (507) 288-2676.

FS 632 — Douglass, White deck/light blue hull. Sails with spinnaker. Superior tilt trailer, outboard mount. \$2,500. Burton McRoy, Macatawa, MI. Days (616) 527-0080, Evenings, (616) 527-1317.

FS 1750 — Douglass. White hull/white deck. 1982 TeeNee Trailer. # sets sails, 2 spinnakers, plus many extras. Sailed on fresh water and is in great condition. \$3,500. Contact Dave Jacobsen, 80 Mountain Road, Woodbury, CT 06798. (H) 263-0769 or (W) (203) 382-7230.

FS 2195 — Douglass. NEW white Durathan hull with blue trim. Bottom has NEW blue Petit Trinidad 75 anti-foul coating. NEW Schreck main & jib. NEW highlander galvanized trailer. Spinnaker with gear. Blue acrylic mainsail cover. 4hp Evinrude Saildrive OB with 3 gallon tank. Has been dry-sailed at Hilton Head. Call: (803) 757-3070 days or (803) 757-2942 nights. Write: John Toth, Box 548, Bluffton, SC 29910. Asking \$4,900.

FS 2308 — Douglass. Aqua hull with white deck, excellent condition, 2 suits sails, plus spinnaker and all gear. Dry sailed only. Motor mount and 5 hp motor, trailer. \$4,150. Atlanta. Contact John Henderson, (W) (404) 581-2647 or (H) (404) 744-6074.

FS 3032 — Customflex. Tangerine hull, white deck. Pamco Trailer. Spinnaker and good working sails. Never raced, dry sailed fresh water. Excellent condition. \$3,850. (518) 477-4870. Located Albany, New York.

FS 3563 — Comes with 2 hp Johnson, Trailer, spinnaker, 2 sets sails, anti-fouling paint, misc. other go fast goodies. Sailed very infrequently. Asking \$5,200. Excellent condition. (914) 658-9101 and leave message or write Steve Axelsson at 59 Main Street, New Paltz, NY 12561.

FS 3779 — Douglass 1982, ivory deck & hull with red stripe. Easy handling for two. Fully equipped for racing with the latest go-fast gadgets. 3 Boston Sails and trailer. \$4,500.00 Call: L. Viemann - Day: (201) 782-9534, Eve: (201) 369-5403.

FS 4141 — '85 Douglass, White hull/deck, sailed one season, Shurr Sails, Full Boat Cover, galvanized Tee Nee Trailer, race equipped, almost new condition, \$7,200. Negotiable. Contact: Jeff Stamper, 6210 Abilene Street, Springfield, VA 22150 (703) 971-7354 or (703) 971-3566.

Looking for a boat?
Call our Hotline for up to the minute, no cost information on Scots for sale. (803) 252-5646. 9 am - 4:30 pm, Monday-Friday.

All submissions will immediately be placed on our phone Hotline list at no additional cost!

FS 3918 — Douglass 1984, always dry-sailed in fresh water—ivory with red stripe, 1985 Schurr Sails with windows, spinnaker, tent cover, anchor & line, motor mount, lifting bridle, mast hinges, Waco 360, Compass. 4 life jackets, full length seat cushions, TeeNee Tilt trailer—perfect condition, asking \$6,900. Location is N. New Jersey. Contact Sandy Bagdan at (201) 267-8818 evenings.

FS 4060 — 1985 Douglass. White hull/deck. Excellent race record including '85 & '86 District Championships. Custom-rigged for the most efficient, simplest, daysailing/racing layout imaginable. Shore Sails. Measurement certificate. Dry sailed, fresh water only. Outstanding condition. Extensive equipment; contact for particulars. \$6,500. Pat Barry, 34090 Parkdale, Livonia, MI 48150. (313) 427-0797.

Article Reprints. New to the Class? Missing previous issues of *Scots n' Water*? Reprints of past articles in *S n' W* are available at \$1 per article, postage included. Such a deal! Contact Editor, Pat Barry, for a free complete list of articles available. 34090 Parkdale, Livonia, MI. 48150. (313) 427-0797 evenings.

Publication Deadlines

Regatta organizers should take note of the following deadlines, since lead-time for regatta notices and regatta reports is longer than you might anticipate.

March issue	Jan 1
May	March 1
July	May 1
September	July 1
November	Sept 1
January	Nov 1

As always, I will hold notices of regattas for 'The Starting Line' open until the last possible minute. Call, if necessary!

FLYING SCOT SAILING ASSOCIATION NEW ACTIVE MEMBERS

Dist.	Fleet	Boat#	Name	Address	City	State	Zip
			1680	Barbara Elster	445 Broadmoor Ave.	Pittsburgh	PA 15228
Carolinas	48	1290	William B. Ross	1504 Laurel Ln.	Gastonia	NC	28054
Carolinas	27	2811	Geoffrey B. Dornback	3029 Rosewood Circle	Durham	NC	27705
Carolinas		4144	Dennis M. O'Donnell	Rt #2, 18710 Bluff Pt. Rd.	Huntersville	NC	28078
Greater N.Y.		4273	Bart C. Codd	174 Brookside Ave.	Staten Island	NY	10314
Greater N.Y.	7	9601	Trever M. Davey	180 Hunter Ave.	N. Tarrytown	NY	10591
Greater N.Y.		4283	B. P. Kuehn	14 Round Hill Rd.	Chappaqua	NY	10514
Greater N.Y.		4277	Marshall R. Lewis	558 Nod Hill Rd.	Wilton	CT	06897
Greater N.Y.		4046	William B. Miller	30 Lisa Dr.	Huntington	CT	06484
Gulf		9670	Eric Durmont Jr.	561 Janwood Dr.	Mobile	AL	36608
Gulf	92	1828	C. R. Slaughter	804 Harbor Ln.	Pascagoula	MS	39567
Michigan-Ontario	148	3694	Ronald & Nancy Clark	L30-C-Young Tract Seneca RR#2	Caledonia	CN	NOA 1A0
Michigan-Ontario	15	3343	Mary Ruth Robinson	Box 3	Richland	MI	49083
Midwestern		1587	Peter R. Langlois	4411 46th St.	Sioux City	IA	51008
Midwestern		4024	Louis Rodencal	1006 W.Beardsley Place	Salt Lake City	UT	84119
New England		0159	Curtis & Joan Barnes	PO Box 426	Nantucket	MA	02554
New York Lake		1930	Arkley L. Mastro Jr.	11 Van Voast Lane	Scotia	NY	12302
New York Lake	161	2726	Cartis & Anne Mills	RD1, Box 364	Gloversville	NY	12028
Ohio		4229	Charles Hoffman	4483 Bredlewood Ln.	Batavia	OH	45103
Ohio		1158	Rick Kleshinski	590 Lexington Ave.	Mansfield	OH	44906
Pacific		1137	William Moseley	P.O. Box 600	Inverness	CA	94937
Prairie	59	1982	Jerry Whitt	3609 East 57th Place	Tulsa	OK	74135
Texas	23	0239	Jim Reeves	1620 St. James	Carrollton	TX	75007



Flying Scot Specialists

8930 Dexter Pinckney Road Office: (313) 426-4155
Pinckney, MI 48169

In Stock: NEW SCOTS with our custom outhaul, cunningham, vang, and jib sheeting; adjustable universal hiking stick. Add our WACO type 360° centerboard control and custom spinnaker gear for a "kind-to-the-crew", race equipped SCOT. TJS rigged SCOTS have won several NACs and fleet championships (and everyone knows it's the boat and not the crew or sails).

Previously owned SCOTS: All with new-boat warranty. Call or write for details.

Parts and Equipment in Stock: All the parts for DOUGLASS or CUSTOMFLEX boats as well as WACO type 360° cleats, crew hiking aid, shroud covers, custom cockpit "tent" covers, stainless or aluminum winch cranks, sailcloth centerboard gaskets, TELO windvanes, plus all the necessary kits to update the rigging for your mainsheet, jib sheet, vang, and spinnaker controls. Do-it-yourself instructions and photos for all our kits.

Check your Gooseneck! We have all the parts to repair the STAR MARINE/KENYON gooseneck. Our uncollapsible universal replaces the inadequate universal which appeared beginning about 1971. \$6.50

Accessories: AIGLE boots, absolutely the best wet sailing dinghy boot; CHUCK ROAST jackets and jumpsuits; HIGH SEAS PVDs and foul weather gear; ACCUSPLIT racing timers, at \$42 the slickest waterproof watch/stopwatch you can buy; LASER compasses, and much more. **Call us for holiday or birthday shopping suggestions.** Catalogue available.

New Items: HARKEN HEXARATHCET® riser, form-fitting molded black plastic platform. No maintenance alternative to wood block to wedge ratchet up to horizontal. Leeward cleating is easy in the heaviest of winds! Now no excuse for cumbersome across-the-cockpit sheeting. \$31 package has (2) risers, fasteners, HARKEN #150 cleat wedges, and instructions.

RACING CLINIC: For beginner/intermediates. Plan now to attend our 1987 clinic, from Friday noon, May 29 thru noon on Sunday May 31 at Portage Lake near Ann Arbor. Single (\$50) and multi-handed (\$90) boats. Scot sailors from as far away as Tennessee, New Jersey, and Minnesota have attended this outstanding event. 12 hours of on-the-water instruction plus lectures and critiques of your video taped performances. Call or write for details.

We ship daily by UPS on open account to FSSA members! We repair hulls, centerboards, and sails.

FSSA District Governors

CAPITOL DISTRICT

Dennis Morris
7412 Elgar St.
Springfield, VA 22151
(703) 256-4276

GULF DISTRICT

Jerry Dees
412 Frederick
Fairhope, AL 36532
(205) 928-0872

MID-WESTERN DISTRICT

Bernie Knight
15999 Quiet Oak Road
St. Louis, MO 63017
(314) 532-9410

OHIO DISTRICT

Chuck Hoffman
4483 Bridlewood Lane
Batavia, OH 45103
(513) 752-4024

CAROLINAS DISTRICT

Robert H. Murdock, Jr.
1404 Oakland Ave.
Durham, NC 27705
(919) 286-0093

GREATER N.Y. DISTRICT

Lawrence McCarthy
67 Great Hill Road
Ridgefield, CT 06877
(203) 438-5008

N.E. DISTRICT

John Clark, Jr.
539 Burroughs Road
Boxborough, MA 01719
(617) 263-2095

PACIFIC DISTRICT

Tim C. McCarthy
Box 414
Diamond Spring, CA 95619

FLORIDA DISTRICT

Charles D. Smith
2325 Canter Club Trail
Apopka, FL 32703
(305) 880-1476

MICHIGAN-ONTARIO DISTRICT

Doug Christensen
9215 McGregor Road
Pinckney, MI 48169
(313) 426-3510

N.Y. LAKES DISTRICT

Graham Hall
87 2nd Ave.
Gloversville, NY 12078
(518) 725-8534

PRAIRIE DISTRICT

Keith W. Fager
8727 EBY
Overland Park, KA 66212
(913) 341-6358

TEXAS DISTRICT

Richard Wade
8723 Barcardi
Dallas, Texas 75238
(214) 349-7512

MY ADDRESS LABEL IS NOT CORRECT

Name _____

Street _____

City _____

State, Zip _____

Change: Temporary Permanent

Please send change of address to:

FSSA, 3008 Millwood Avenue, Columbia, SC 29205

Second Class Postage Paid
at Columbia, SC 29201